

In this paper I will discuss the basic steps required to build an RS-232 Level shifter for connecting an OOPic™ I to a laptop or desktop computer. You can modify these steps, as needed depending upon which devices you are trying to connect together. You will need to purchase a DS275 chip from: http://www.maxim-ic.com/quick_view2.cfm?qv_pk=2929 Be sure to specify the 8-pin DIP configuration, as this is the easiest to work with in terms of soldering. Below is a schematic of the pin-out for the DS275 and a description of the pins.

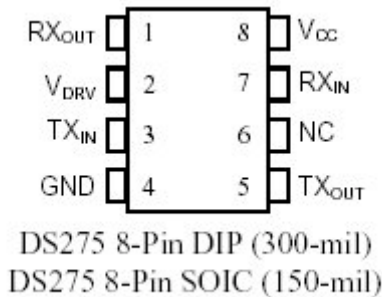

Pin Descriptions:

RX _{OUT}	-RS-232 Receiver Output
V _{DRV}	-Transmit driver +V
TX _{IN}	-RS-232 Driver Input
GND	-System Ground
TX _{OUT}	-RS-232 Driver Output
NC	-No Connection
RX _{IN}	-RS-232 Receive Input
V _{CC}	-System Logic Supply (+5V)

You will also need a small proto-board, DB9 female connector, 4-conductor wire, and appropriate end connectors. All these supplies can be found on-line and I have put together a small list with the parts and corresponding part numbers. You will also need an 8-Pin IC-Socket for holding the DS-275. I prefer not soldering the chip directly. Note that the parts list below does not list the 4-conductor cable as I assume you will have your own wire.

1	WM2200-ND	Package of 10 crimp terminals	0.67	0.67	www.digikey.com
1	WM2000-ND	2-pos 0.1" female connector	0.23	0.23	www.digikey.com
1	23-5905	DB9 female conn. w/solder cups	0.45	0.45	www.unicornelex.com
1	32-3006	2.90"x1.70" Proto-Board	1.19	1.19	www.unicornelex.com
1	WM2003-ND	5-pos 0.1" female connector	.42	0.42	www.digikey.com

Step1:

Solder the 8-pin IC-Socket to your proto-board. Solder in a jumper wire from pin2 to pin 8 on the IC socket. This will connect V_{DRV} to V_{CC} on the DS275.

Step2:

Determine which color wires you will be using for what from the DB9 connector to the DS275 chip and then make the solder connections. I will be using the color scheme described below.

Green wire-Pin#3 on DB9 connector and connect to Pin#7 on DS275

White wire-Pin#2 on DB9 connector and connect to Pin#5 on DS275

Black wire-Pin#5 on DB9 connector and connect to Pin#4 on DS275

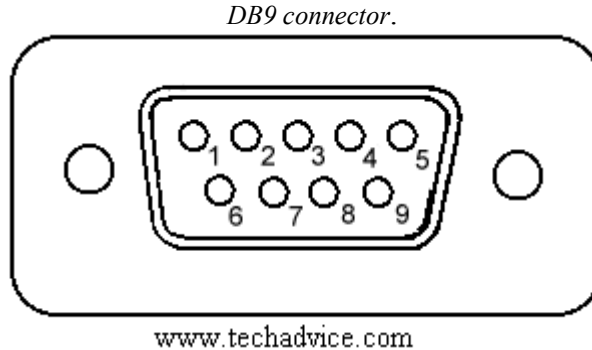

Step3:

Determine which color wires you will be using for what from the DS275 chip to the OOPic I and then make the appropriate solder and crimp connections. I will be using green, white, black, and red wires. The connections for these wires will be as follows:

Green wire- Pin#3 on DS275 and connect to Pin#37 on OOPic I/O connector

White wire- Pin#1 on DS275 and connect to Pin#39 on OOPic I/O connector

Black wire- Pin#4 on DS275 and connect to Pin#24 on OOPic I/O connector

Red wire- Pin#8 on DS275 and connect to Pin#22 on OOPic I/O connector

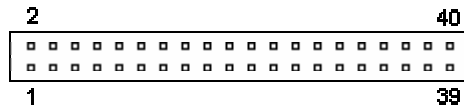

OOPic I/O connector.

Finally, attach the appropriate end connectors and you will have a completed level shifter cable! I used a 5-pos and a 2-pos Molex connector on the cable below, since it is for connecting an OOPic to a desktop or laptop computer.

