

Building a Cable for a NewCDBot Light/Temperature Sensor

In this article I will cover the steps needed to build a cable for the light and temperature sensors that are used on the NewCDBot. Below is a short list of materials and tools that will be required.

Materials:

Light/Temperature Sensor Cable					
Qty.	Part#	Description	Price	Total	Where to Get?
1	SCRAP	8-inch length of red 22-24 gauge wire	0	0	Home
1	SCRAP	8-inch length of orange 22-24 gauge wire	0	0	Home
1	SCRAP	8-inch length green of 22-24 gauge wire	0	0	Home
1	157382	3-Position Non-Polarized Connector	0.24	0.24	www.jameco.com
2	100811	2-Position Non-Polarized Connector	0.23	0.46	www.jameco.com
5	100765	Female Crimps	0.11	0.55	www.jameco.com
1	136055	Photocell	0.89	0.89	www.jameco.com
1	271-0110	Thermistor	2.49	2.49	www.radioshack.com
1	108121	10K-Ohm 1/8 resistor	0.69	0.69	www.jameco.com
Total Cost			5.32		

Tools:

1. A pair of wire cutters. You can use a pair of scissors.
2. A good wire stripper that can strip 22-24 gauge wires. Jameco Part#78991, \$3.95
3. Wire crimper for crimping the female crimps. Jameco Part#99442, \$8.95

Now that you have all the necessary materials and tools, let's get started building the cable. First, cut (3)-pieces of wire to 10-inch lengths and then strip back the end of each piece by approximately 1/8" as shown below.

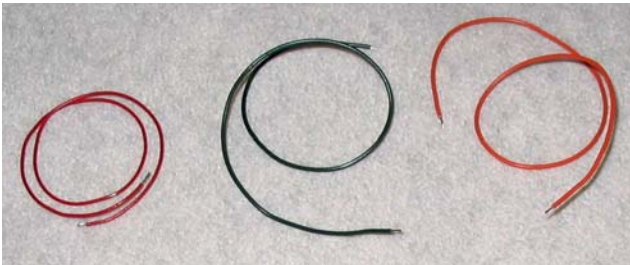

Figure#1. Wires cut to length and striped.

Next, take the orange wire and crimp a female crimp pin onto each end. There are two crimp points on the female crimp pins. Be sure that the bare wire is situated under the crimp point that is furthest from the end of the pin that was attached to the roll and then crimp using the hand-crimp tool. Your orange wire should now appear as shown below.

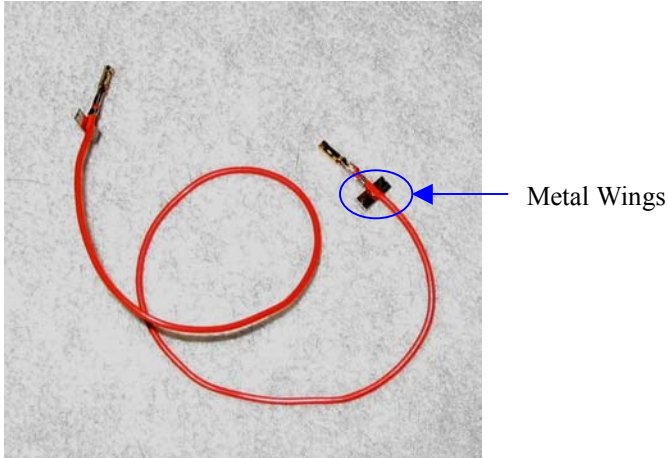

Figure#2. Orange wire with female crimps.

Next, attach crimps to each end of the green and red wire. Once you have completed the crimping you will need to remove the little metal wings that are left on each of the crimps. You can firmly hold the crimp and bend the metal wing back and forth until it breaks off. Next, take the 3-position connector and insert the (3)-wires as shown below.

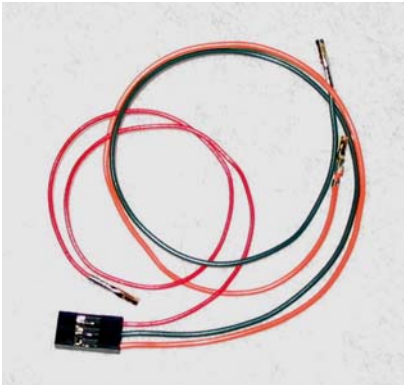

Figure#3. Wires inserted into 3-position connector.

Finally, insert the red and black wire into a 2-position connector and then insert the orange wire into a separate 2-position connector as shown below.

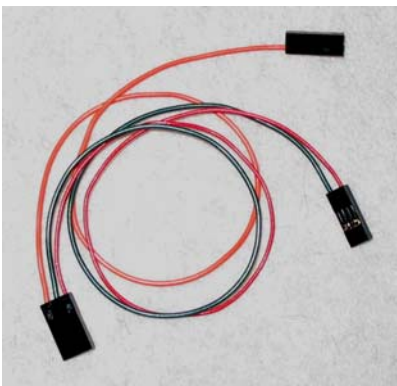

Figure#4. Wires inserted into 2-position connectors.

You have now completed your very own light/temperature sensor cable.

If you want to construct a light sensor you will need an appropriate photocell and 10K-Ohm resistor. You will need to solder the photocell and 10K resistor as shown below.

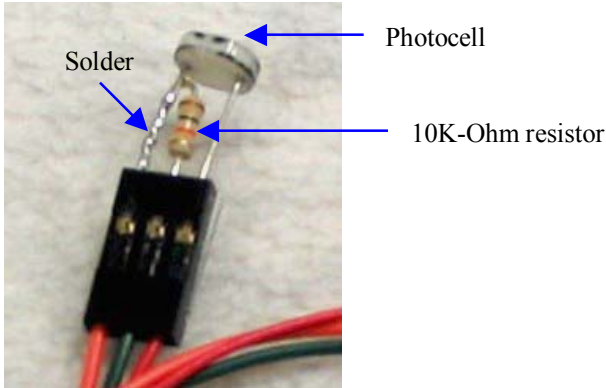

Figure#5. Photocell sensor.

Below is a simple schematic that is representative of the light sensor.

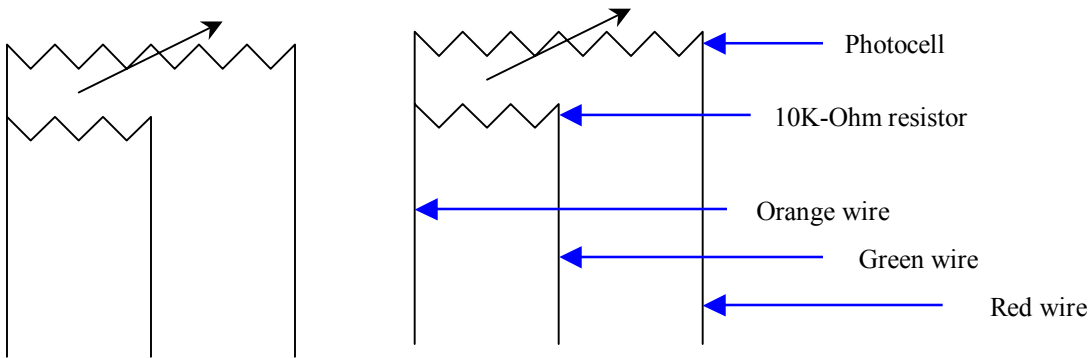

Figure#7. Light sensor schematics.

If you want to construct a temperature sensor you will need an appropriate thermistor and 10K-Ohm resistor. Next, you will need to solder the thermistor and 10K resistor as shown below.

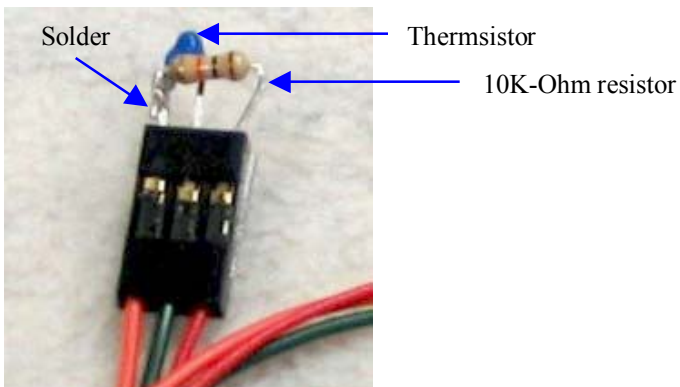

Figure#6. Temperature sensor.

Below is a simple schematic that is representative of the temperature sensor.

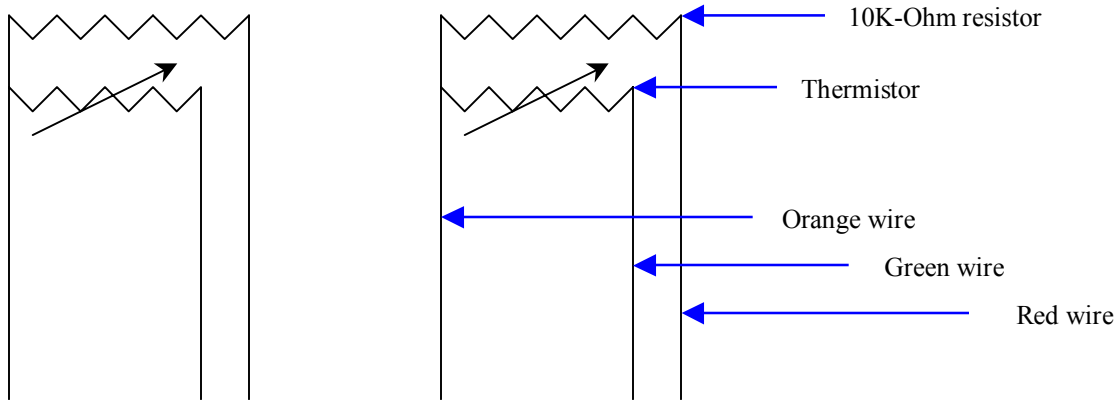

Figure#8. Temperature sensor schematics.

If you have any questions please send an e-mail to abe@abotics.com.