

Abe Howell's NewCDBot™ Kit With Bumper Switch Sensors Assembly Instructions

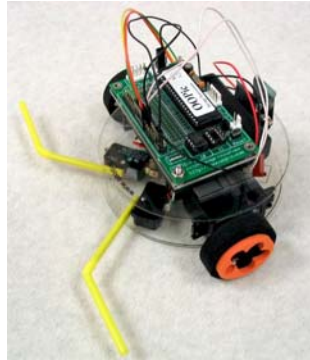

The NewCDBot Kit is not a toy and is to be used by adults or supervised by adults!

We assume no responsibility for any and all damage that may occur to the kit during the assembly process, so please be careful. Partially assembled or opened kits will not be returnable. If you have any reservations with regards to this kit, please return it immediately before opening the sealed plastic bag. Please send any questions to abe@abotics.com. We hope you have an enjoyable robotics experience!

These instructions assume that you have the NewCDBot Robot Kit with bumper switch sensors and that the reclosable tape has already been properly cut and placed. The following instructions will lead you through the entire assembly and wiring process. OOPic is a Trademark of Savage Innovations Inc.

The first step involves attaching the modified hobby servos to the bottom CD. The bottom CD is the one with the little white roller wheel. Be sure that the servos are attached so that the foam wheels are further away from the roller wheel as shown above. The end with the roller wheel is the back of the NewCDBot and the other end is the front.

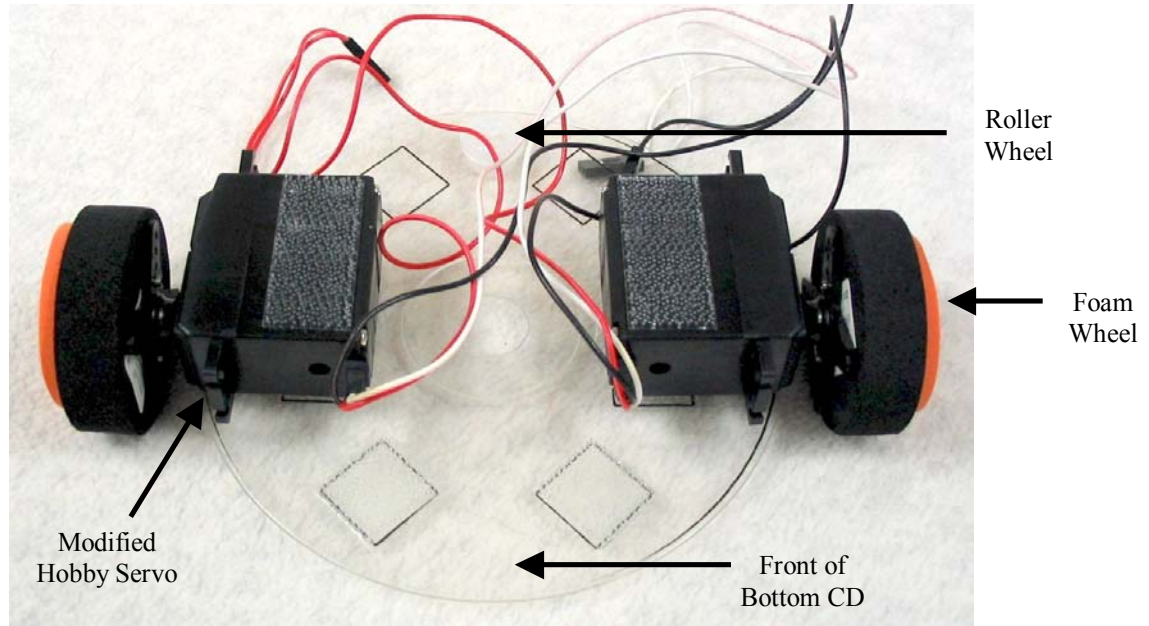

Step1. Attach the modified servos.

The bumper switch sensors will be assembled in step2. There are two pads of reclosable tape that are positioned in front of the two modified servos; this is where the bumper switch sensors attach. Simply press the switches into place as shown below.

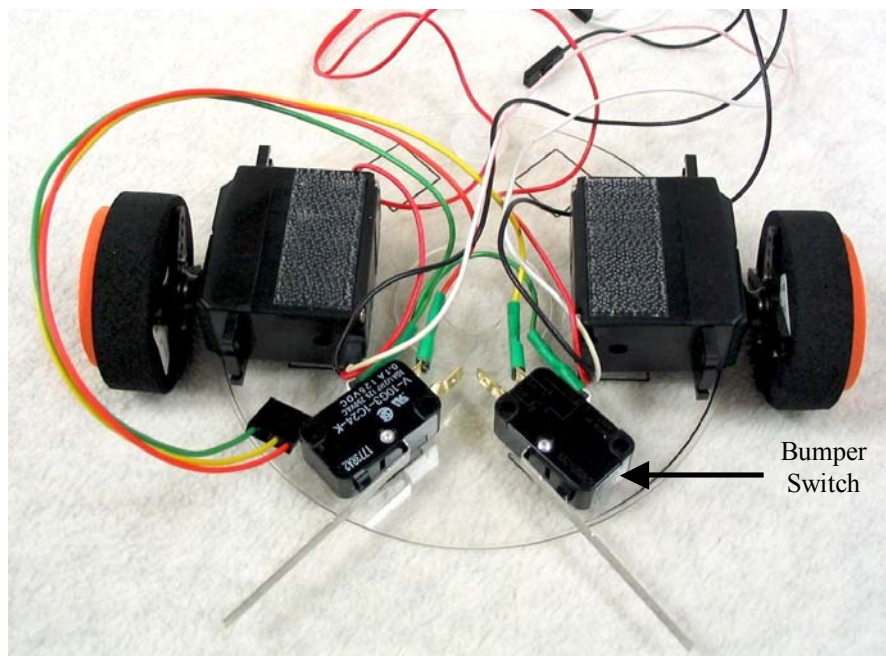

Step2. Attach Bumper Switch Sensors to Bottom CD.

In step3 we will be attaching the top CD. The top CD is the one without the roller wheel and also has the words “www.abotics.com” printed on it. Each of your servos will have a black wire, a red wire, and a white wire. Be sure to feed the white and black wires of each servo through the center hole in the top CD. Also feed any wires from your bumper switch sensors through the top CD’s center hole. Don’t feed the red wires of each servo through the center hole of the top CD; simply leave the red wires alone for now and let them stick out the back of your NewCDbot.

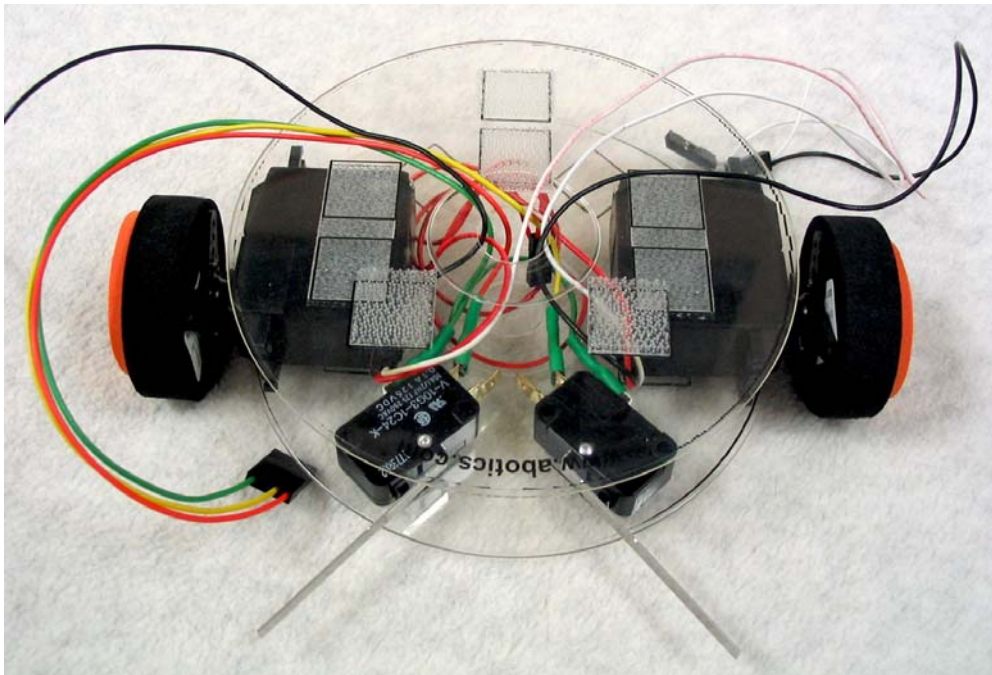

Step3. Attach the top CD.

In step4 we will prepare to assemble the AA-battery holder by inserting its red wire with the connector that has two small metal pins into the center hole of the top CD. This red wire with connector will provide power to the servos. Don’t insert the red wire that is attached to the connector with the black wire! This is not the right wire!

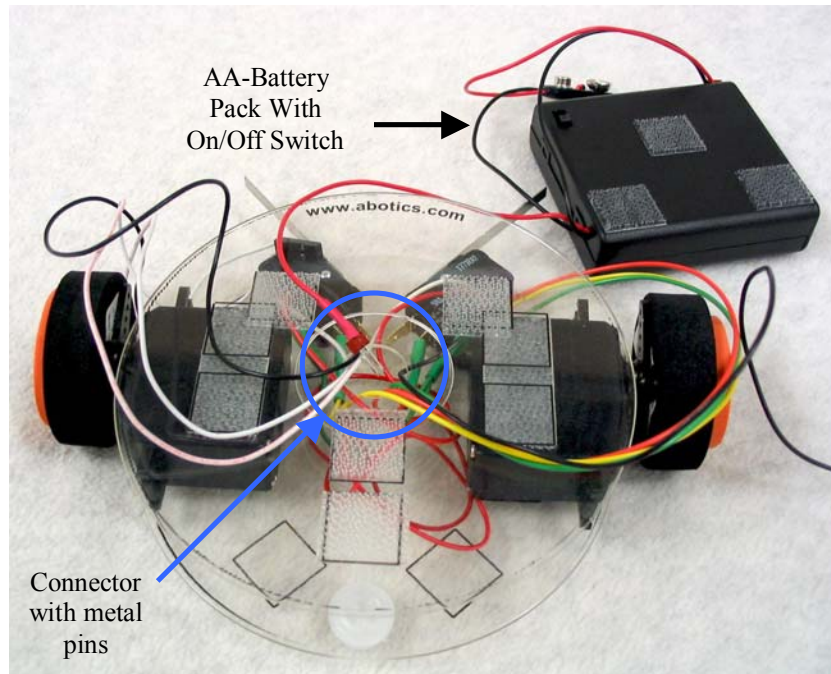

Step4. Prepare to attach AA-Battery holder to top CD.

In step5 we will attach the AA-battery holder to the top of the top CD as shown below in the ste5 picture. Before attaching the AA-battery holder insert (4)-AA batteries. There should be three pieces of reclosable tape on the top of the top CD, which match up with the three pieces on the bottom of the AA-battery holder. The top of the AA-battery holder is the side with the small on/off switch. The switch on the AA-battery pack should be facing the back of your NewCDbot. Also attach the 9-volt battery clip.

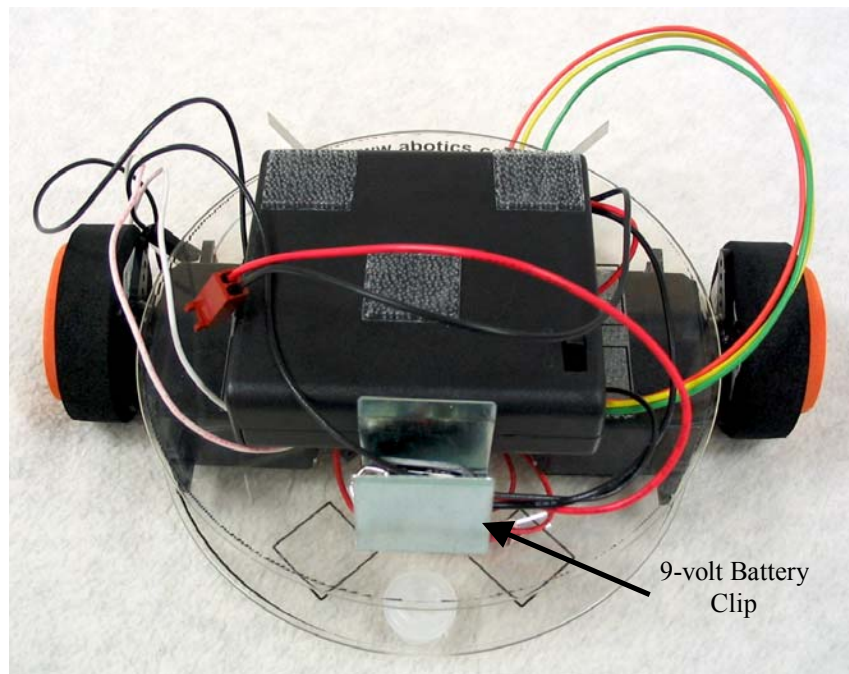

Step5. Attach AA-Battery holder & 9-volt battery clip.

In step6 we will prepare to connect the two red servo wires to the servo power connector by pulling each of the red servo wires out the back of the NewCDBot as shown below in the step6 picture. Also pull out the red wire with the connector that has two metal pins. This is the same red wire that you pulled through the center hole on the top CD in step4. We will also attach the OOPic micro-controller and the plastic mounting deck to the top of the AA-battery holder as shown in the step6 picture. There should be three pieces of reclosable tape on the top of the AA-battery holder that match up with the three pieces on the bottom of the plastic mounting deck. You can attach it to the top of the AA-battery holder by simply pressing it into place. The OOPic should already be mounted to the plastic mounting deck, but if not refer to the following instructions: There should be two 4-40 size machine screws attached to the OOPic mounting deck. Simply align the OOPic controller with the two 4-40 machine screws and gently press it onto the OOPic mounting deck. Next, secure the OOPic controller to the mounting deck with the last two 4-40 nuts.

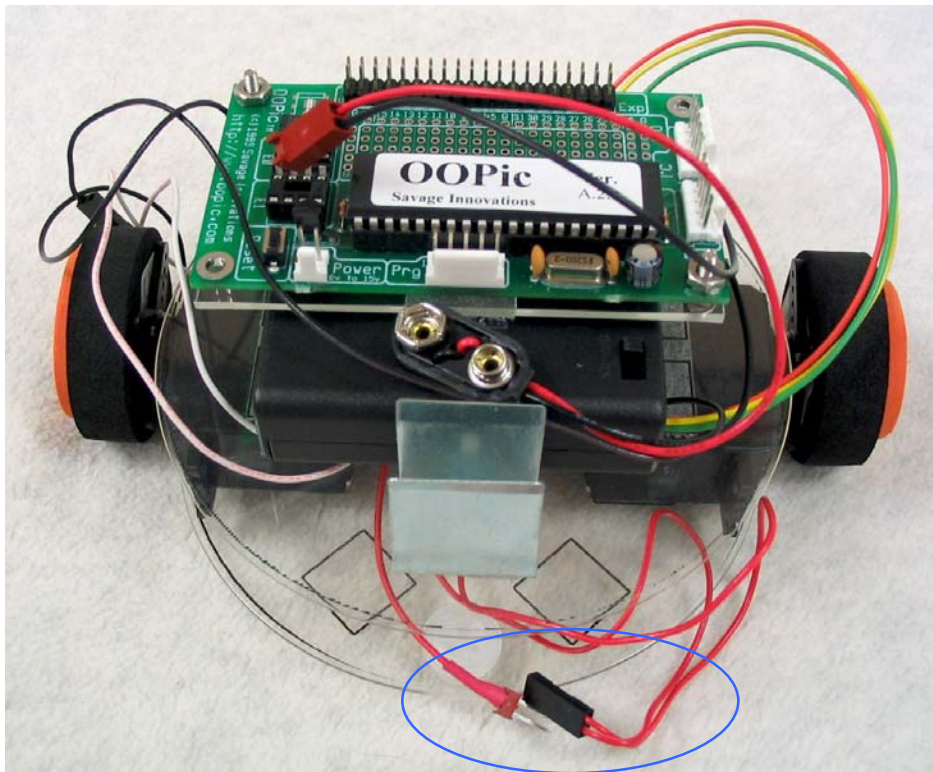

Step 6. Prepare to connect the two red servo wires to the servo power connector.

In step seven connect the two red servo wires to the servo power connector as shown below in the step7 picture.

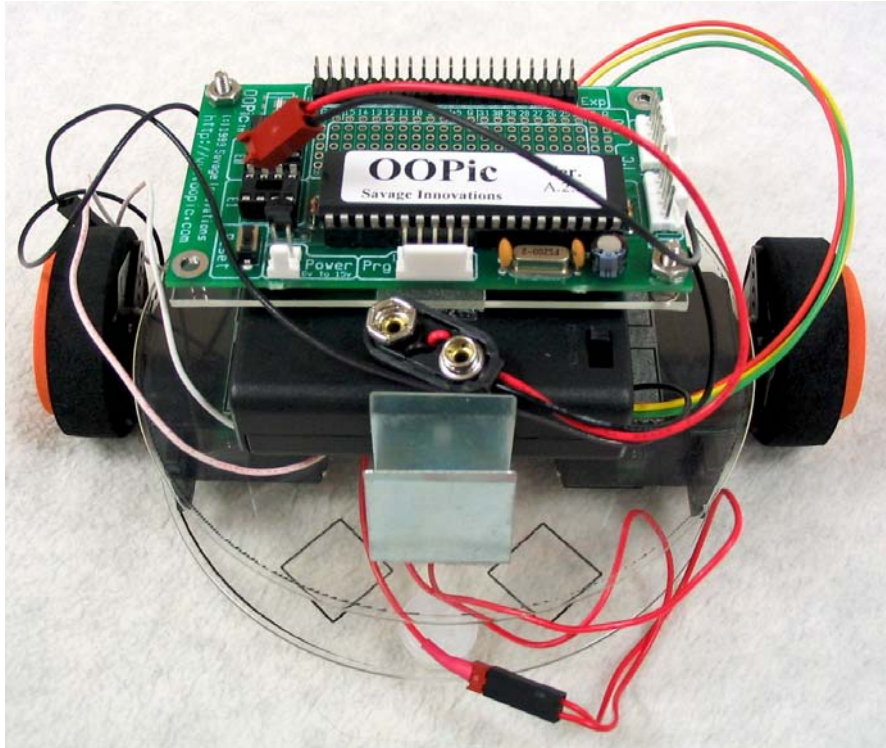

Step7. Connect the two red servo wires to the servo power connector.

In step8 we will hide the red servo wires and servo power connector by curling them up and placing them in between the top and bottom CD.

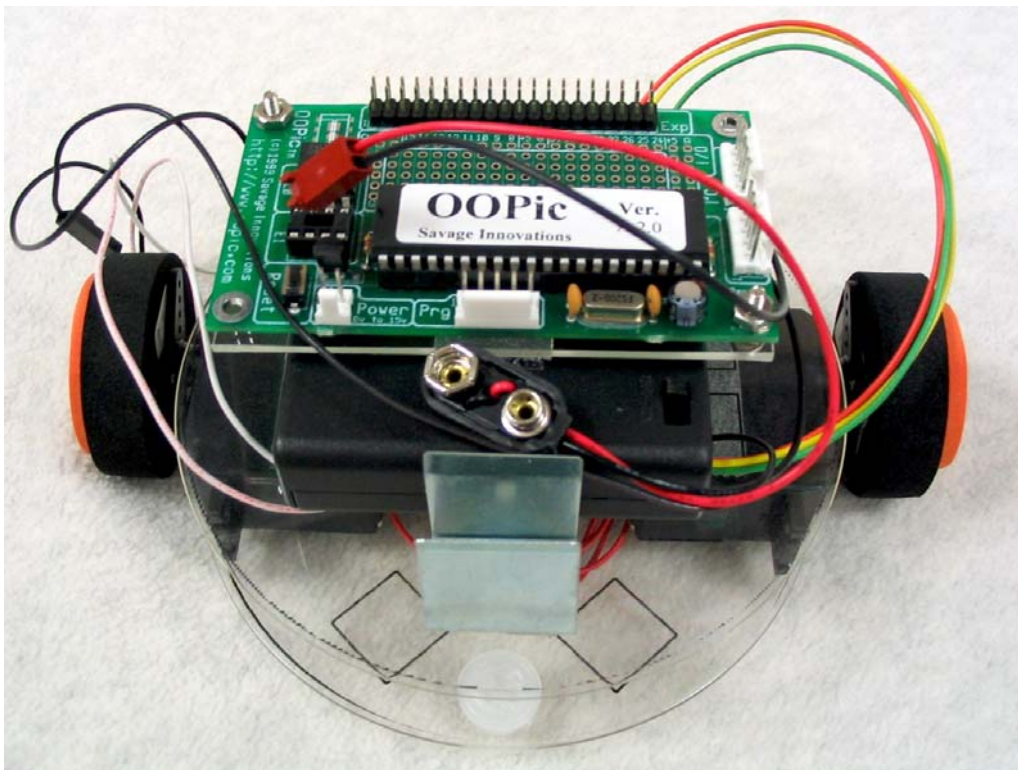

Step8. Hide the red servo wires and servo connector.

We are finally finished assembling the body of our NewCDbot and can now move onto the electronic connections. We will begin step9 by connecting the black wires from each modified hobby servo to the OOPic controller as shown below in the step9 picture. One of the black servo wires should be connected to pin#2 on the OOPic's I/O connector and the other black servo wire should connect to pin#2 on one of the OOPic's Network connectors. Please refer to the diagrams labeled Black Servo wire I/O connector and Black Servo wire Network connector for the proper pin locations and wire connections. These diagrams are displayed below.

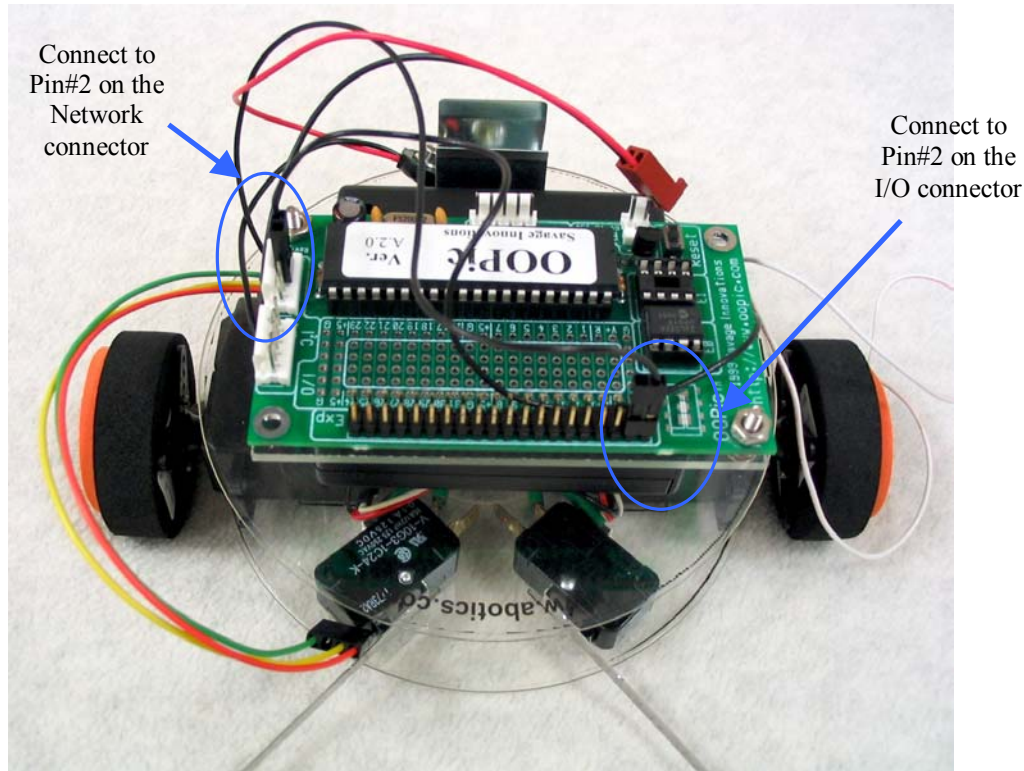

Step9. Connect the black servo wires.

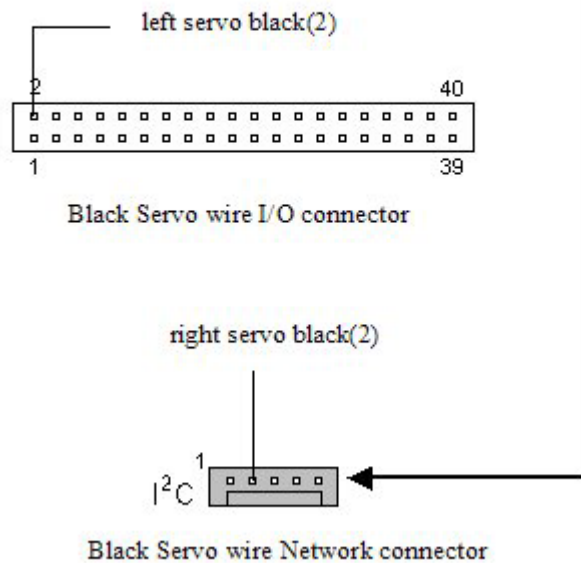
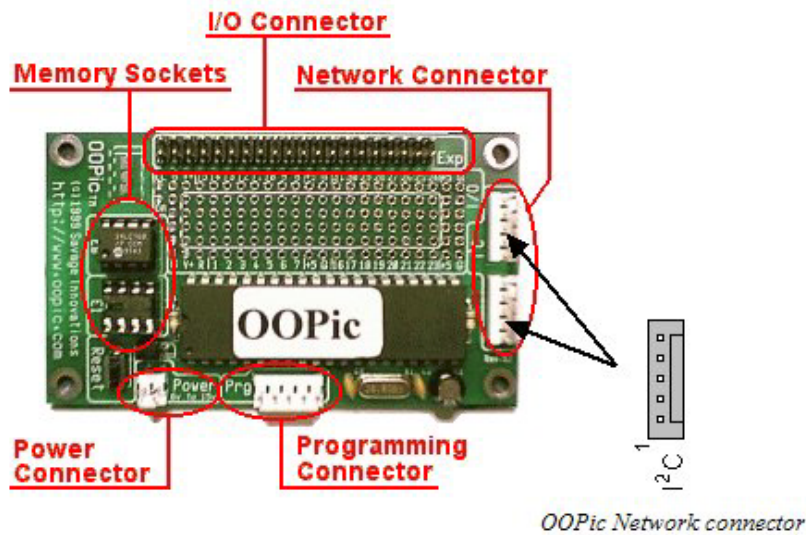
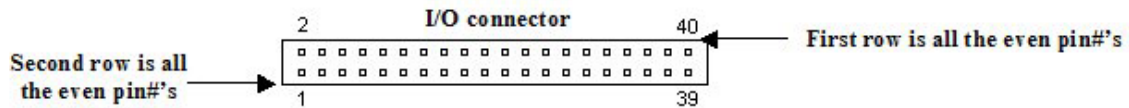

In step10 connect each of the white servo wires to their proper place on the OOPic controller. The white wire from the right servo must connect to pin#17 on the OOPic's I/O connector and the white wire from the left servo must connect to pin#15 on the OOPic's I/O connector. Please refer to the diagram labeled White Servo wires to I/O connector for the proper pin connections. The right servo is the servo that is to the right when viewing the front of the NewCDBot.

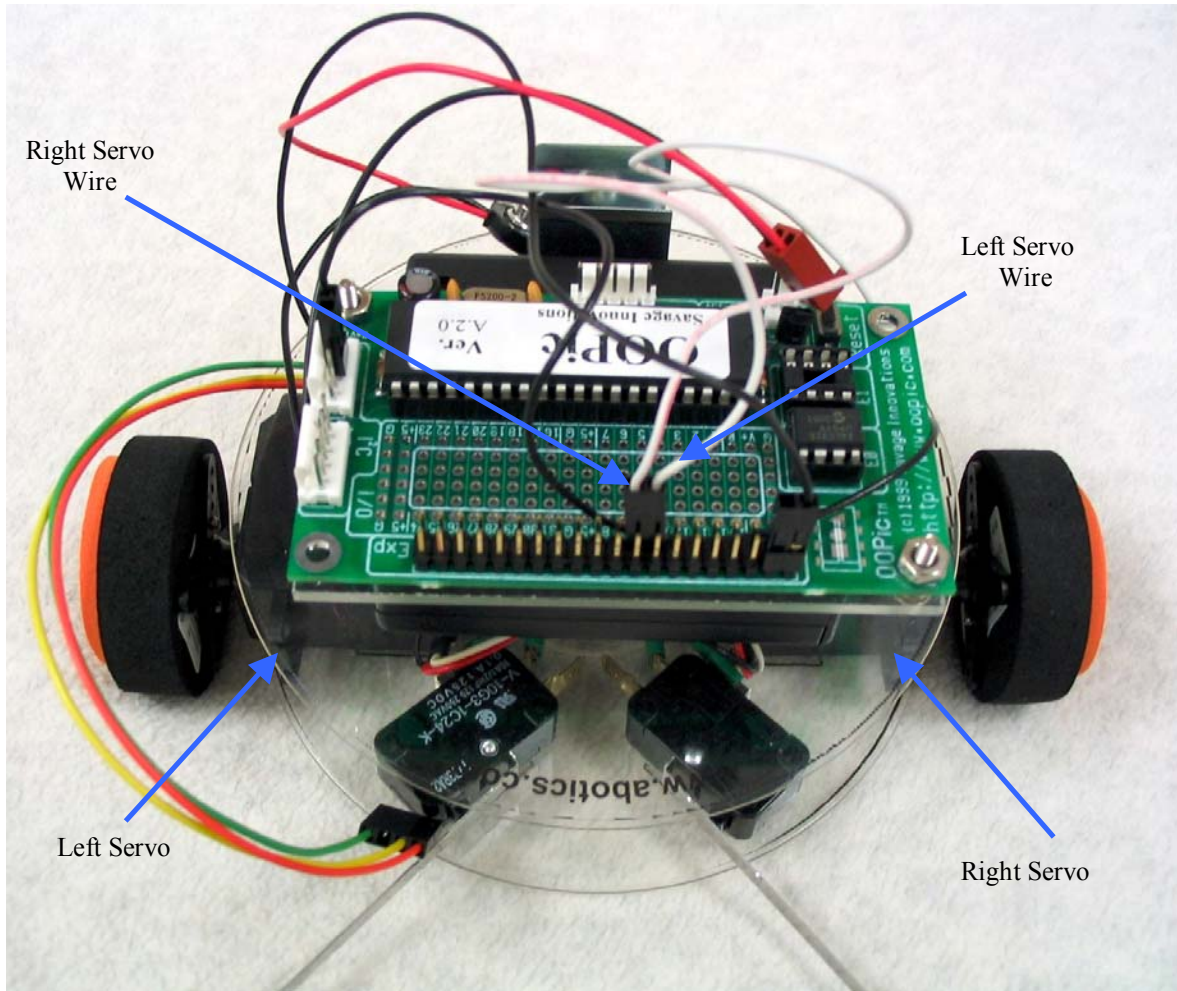

Step10. Connect the white servo wires to the OOPic I/O connector.

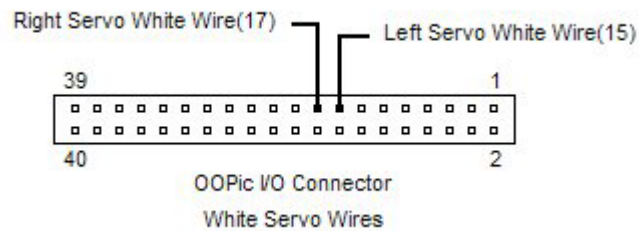

In step11 we will connect the bumper switch connector to the OOPic's I/O connector. Please refer to the diagram below for the correct pin# connections that need to be made on the OOPic's I/O connector. If you improperly connect the connector you may damage the OOPic! So please be careful and take time to complete this section. When possible ask someone to double-check your wire connections. Please refer to the diagram labeled Bumper Switch IO connections for the proper pin connections.

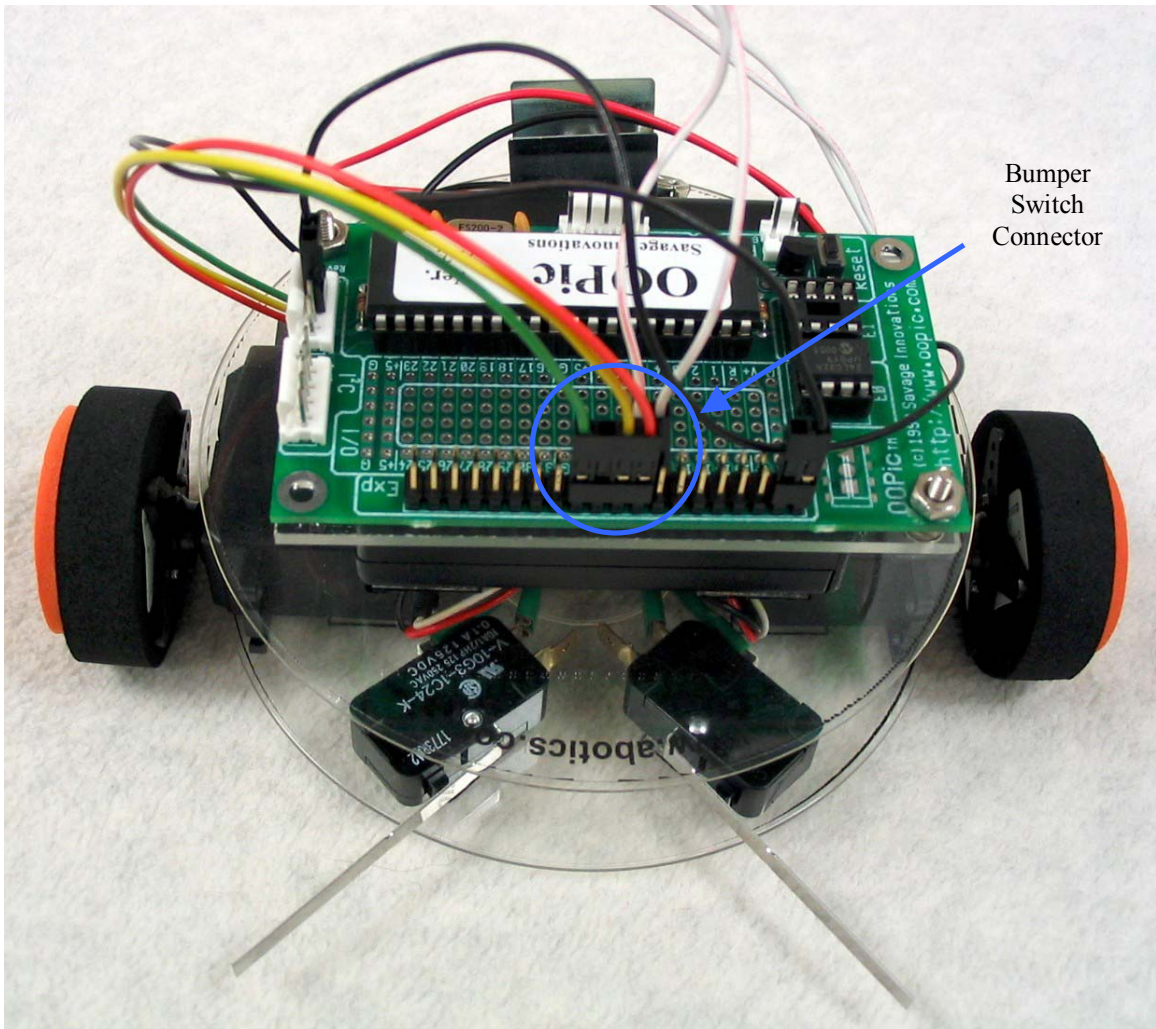

Step11. Connect the Bumper Switch connector to the OOPic I/O Connector.

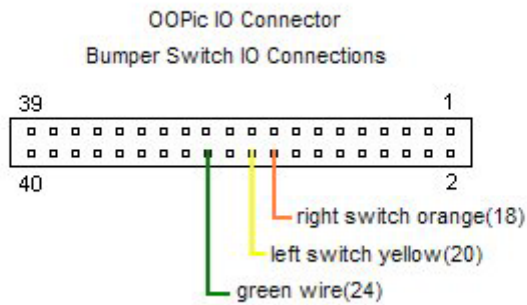

In step12 attach the whiskers to the bumper switches by simply sliding them onto the bumper switch levers. Then adjust the whiskers as you see fit.

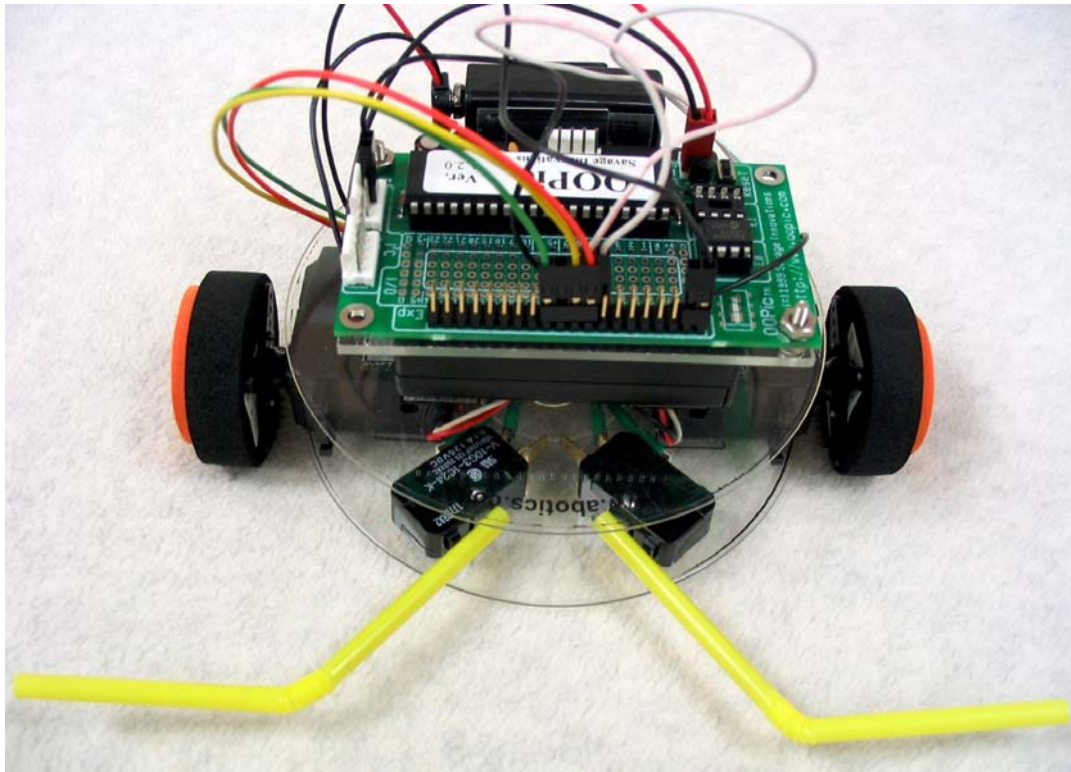

Step12. Attach the bumper switch whiskers.

In step13 take the red connector from the AA-battery holder, which has a black and red wire and connect it to the power connector on the OOPic. It will only connect one way so don't force the connector; try to align the small ribs on the connector. Also insert a 9-volt battery into the 9-volt battery clip and connect the 9-volt connector.

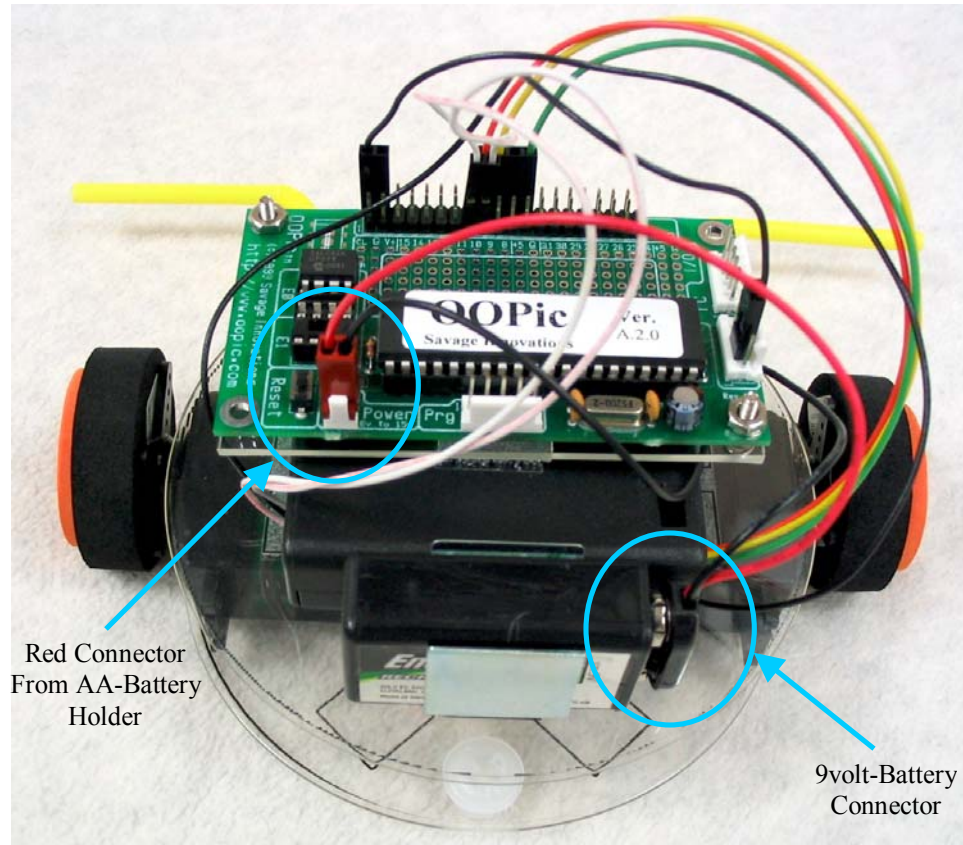

Step13. Connect the AA-battery connector to the OOPic & connect a 9-volt battery.

Congratulations! You have just completed the assembly of your very own NewCDbot Robot! If you are ready to write some code for your NewCDbot, please refer to the first online tutorial for the "CDbot Programmer Compiler", http://www.abotics.com/cdbot_robot_software.htm, it will help you to get started programming your NewCDbot.