

Abe Howell's NewCDBot™ Kit Assembly Instructions

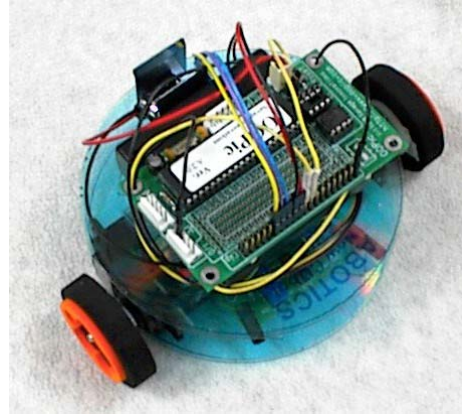

The NewCDBot Kit is not a toy and is to be used by adults or supervised by adults!

We assume no responsibility for any and all damage that may occur to the kit during the assembly process, so please be careful. Partially assembled or opened kits will not be returnable. If you have any reservations with regards to this kit, please return it immediately. Please send any questions to abe@abotics.com. We hope you have an enjoyable robotics experience!

These instructions assume that you have the NewCDBot Robot Kit and that the reclosable tape has already been properly cut and placed. If the reclosable tape has not yet been cut and placed, please refer to "New_CDBot_Kit_Reclosable_Tape.pdf". The following instructions will lead you through the entire assembly and wiring process.

These instructions will take you through the assembly process for a NewCDBot with a Lynxmotion IRPD-01 sensor.

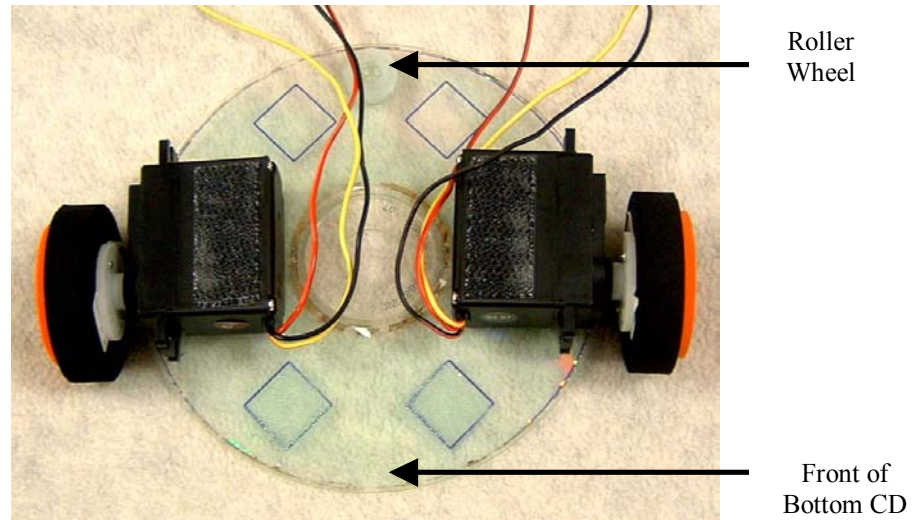

Step1. Attach the modified servos.

The first step involves attaching the modified servos to the bottom cd. The bottom CD is the one with the little white roller wheel. Be sure that the servos are attached so that the foam wheels are further away from the roller wheel as shown above. The end with the roller wheel is the back of the NewCDBot and the other end is the front.

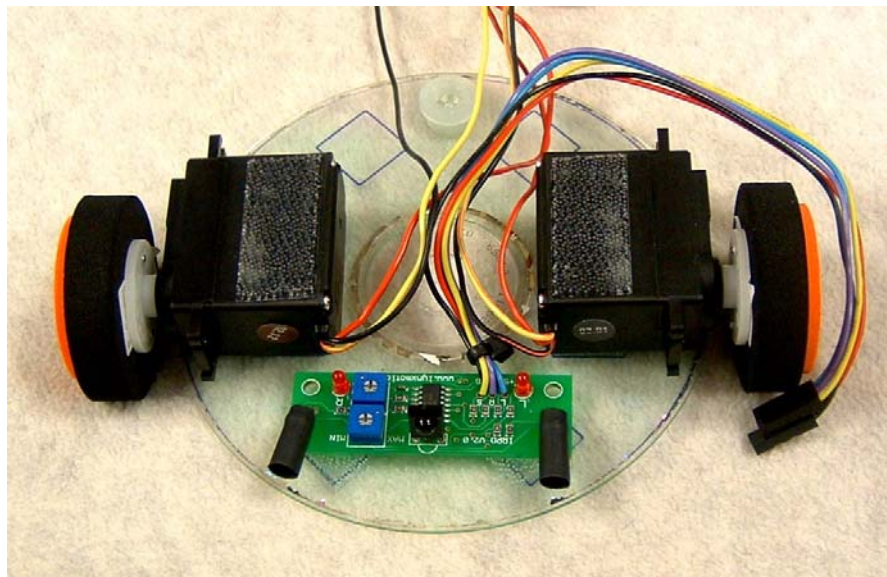

Step2. Attach Lynxmotion IRPD-01 Sensor to Bottom CD.

The Lynxmotion IRPD obstacle sensor will be assembled in the second step. There are two pads of reclosable tape that are positioned in front of the two modified servos; this is where the IRPD sensor attaches. Simply press the sensor into place.

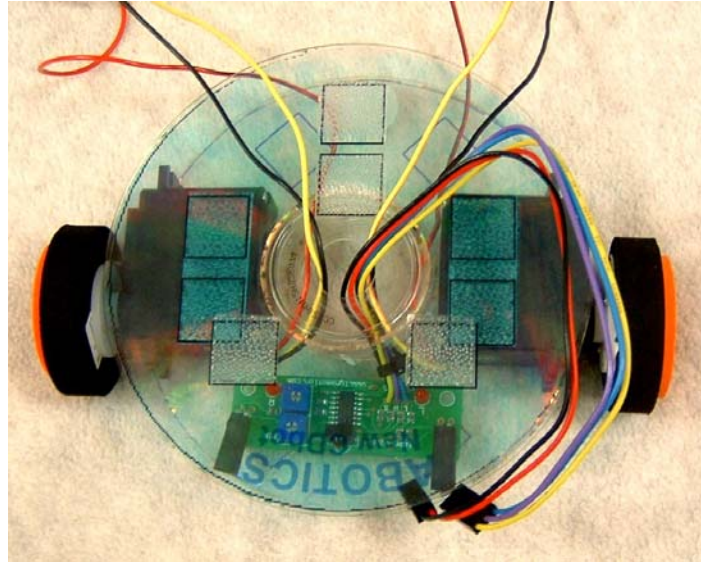

Step3. Attach the top CD.

In the third step we will be attaching the top CD. The top cd is the one without the roller wheel and also has the words “ABOTICS NewCDbot” or “www.abotics.com” printed on it. Each of your servos will have a black wire, a red wire, and either a white or yellow wire. Be sure to feed the white/yellow and black wires of each servo through the center hole in the top cd. Also feed any wires from your obstacle sensors through the top cd’s center hole. Don’t feed the red wires of each servo through the center hole of the top CD; simply leave them alone for right now and let them stick out the back of your NewCDbot.

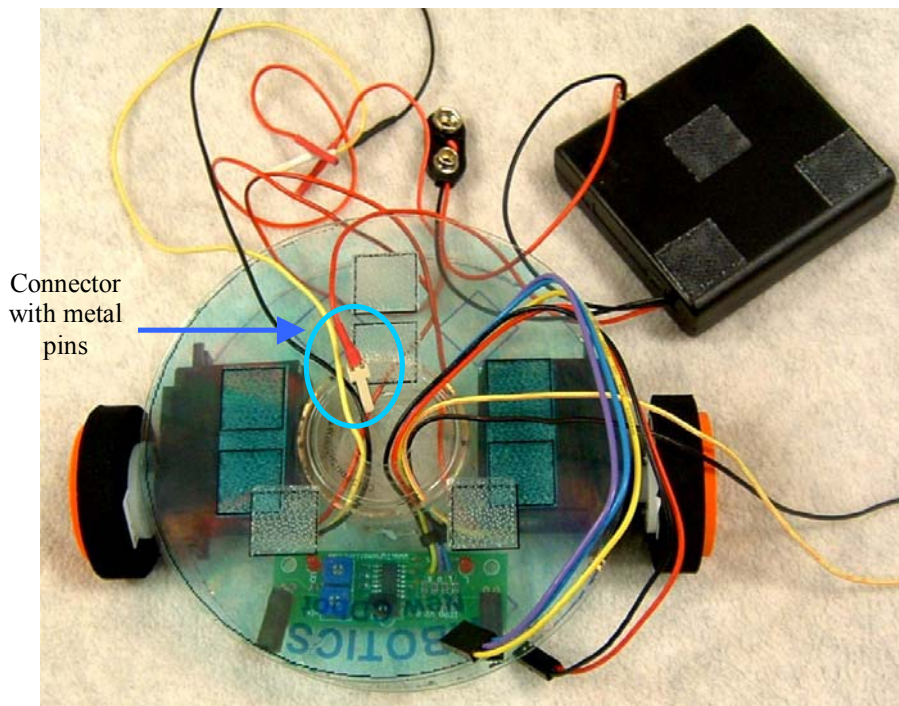

Step4. Prepare to attach AA-Battery holder to top CD.

In step four we will prepare to assemble the AA-battery holder by inserting its red wire with the connector that has two small metal pins into the center hole of the top CD. Don't insert the red wire that is attached to the connector with the black wire! This is not the right wire!

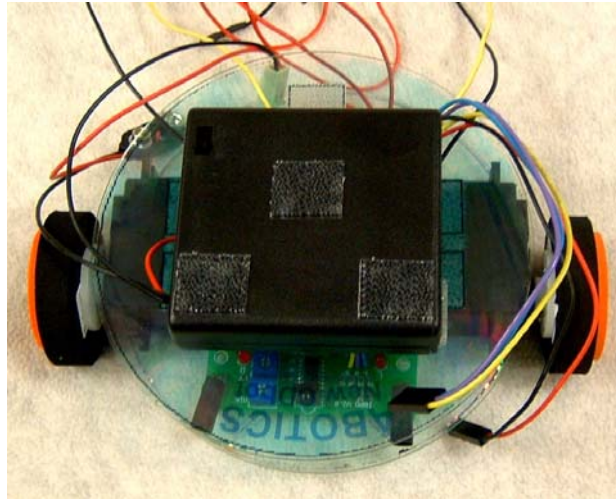

Step5. Attach AA-Battery holder.

In step five we will attach the AA-battery holder to the top of the top CD as shown above. Before attaching the AA-battery holder insert (4)-AA batteries. There should be three pieces of reclosable tape on the top of the top CD, which match up with the three pieces on the bottom of the AA-battery holder. The top of the AA-battery holder is the side with the small on/off switch. The switch on the AA-battery pack should be facing the back of your NewCDbot.

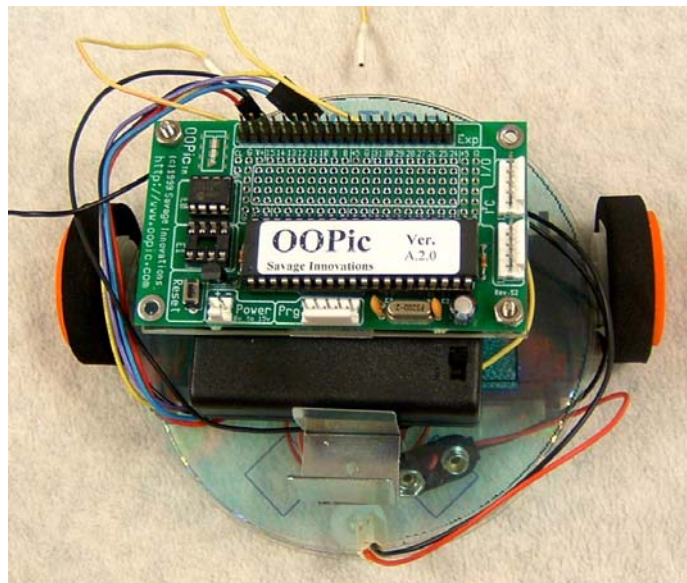

Step 6. Attach clear plastic OOPic mounting deck and secure with 4-40 nuts.

In step six we will attach the OOPic micro-controller and the clear plastic deck to the top of the AA-battery holder as shown above in the step6 picture. There should be three

pieces of reclosable tape on the top of the AA-battery holder that match up with the three pieces on the bottom of the clear plastic OOPic mounting deck. You can attach it to the top of the AA-battery holder by simply pressing it into place. There should be two 4-40 size machine screws attached to the OOPic mounting deck. Simply align the OOPic controller with the two 4-40 machine screws and gently press it onto the OOPic mounting deck. Next, secure the OOPic controller to the mounting deck with the last two 4-40 nuts.

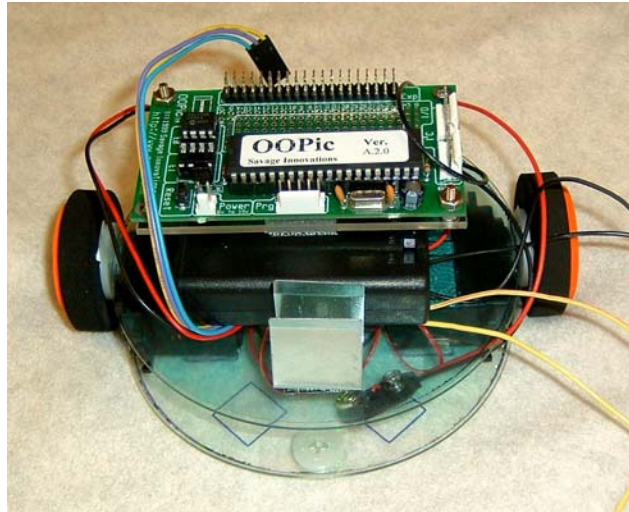

Step7. Attach the 9-volt battery holder.

In step 7 attach the 9-volt battery holder to the top of the top CD by simply pressing it into place behind the AA-battery holder as shown above in the step7 picture.

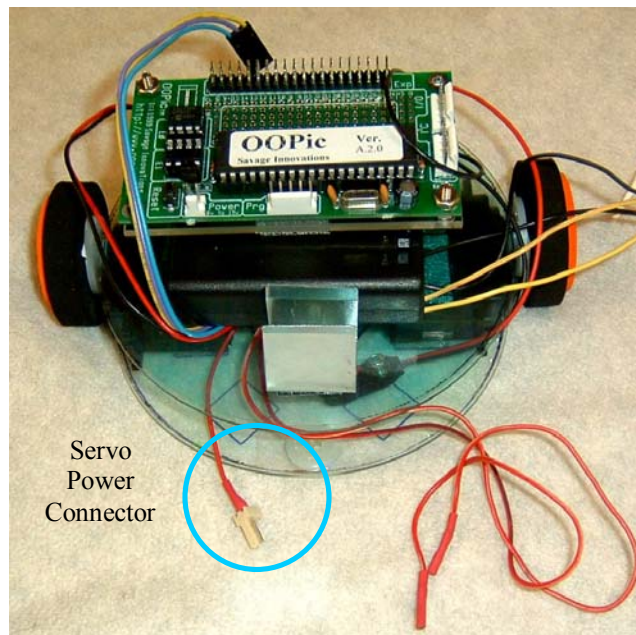

Step8. Prepare to connect the red servo wires.

In step eight prepare to connect the two red servo wires to the servo power connector by pulling each of the red servo wires out the back of the NewCDbot as shown above in the

step8 picture. Also pull out the red wire with the connector that has two metal pins. This is the same red wire that you pulled through the center hole on the top CD in step4.

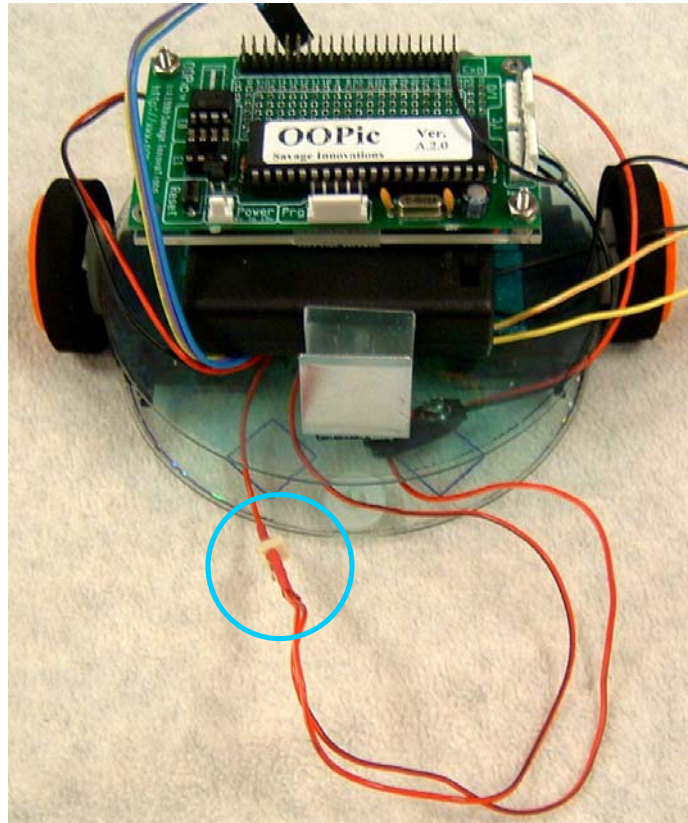

Step9. Connect the red servo wires.

Now connect each of the red servo wires to a metal pin on the red wire with the two metal pins as shown above in the step9 picture.

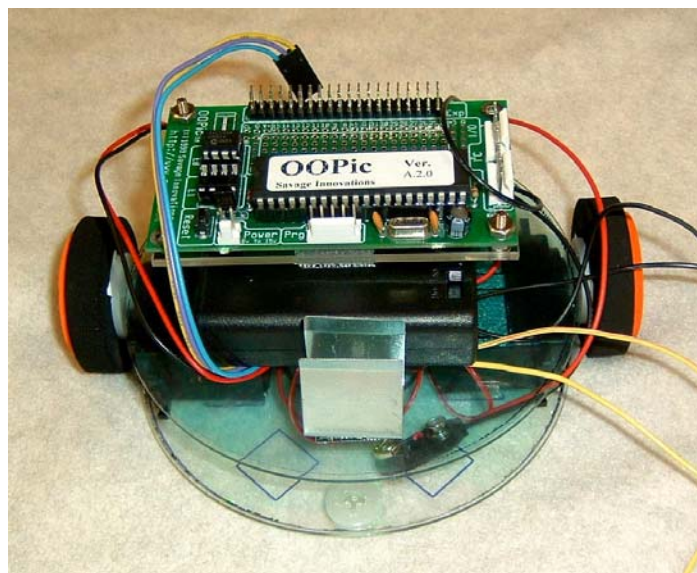

Step10. Hide the red servo wires.

Now in step10, take the red wires that you just connected in step9 and push them in between the CDs so that they are hidden in the middle of your NewCDbot. Don't force the wires, simply curl them up and gently push them into place.

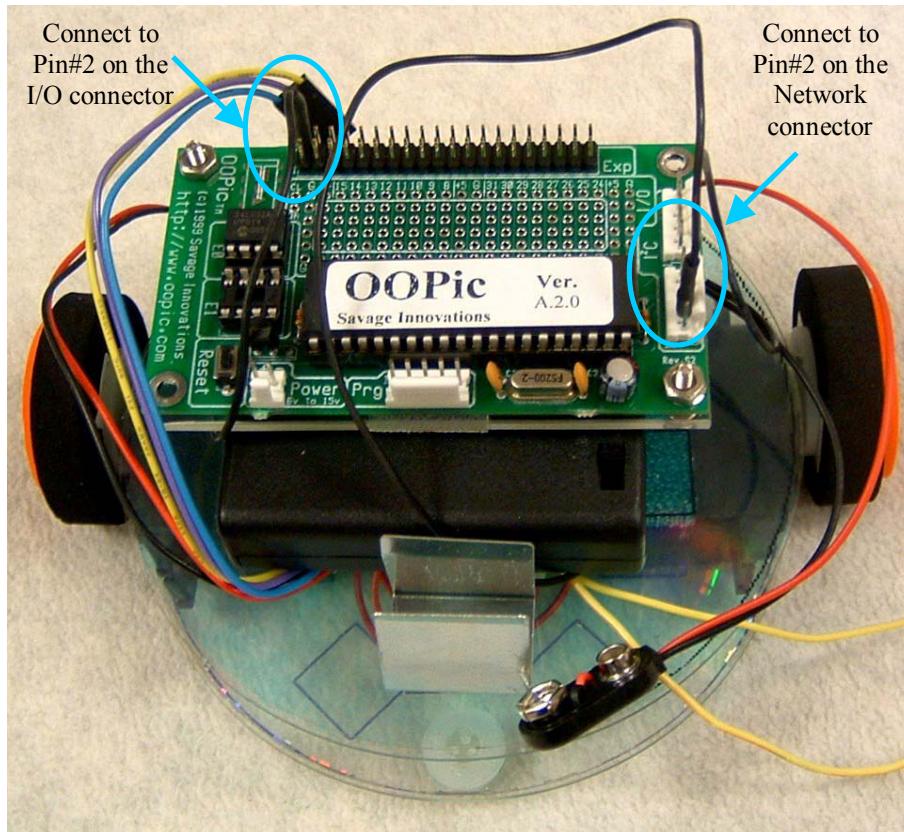

Step11. Connect the black servo wires.

We are finally finished assembling the NewCDbot's body and can now move onto the electronic connections. We will begin step 11 by connecting the black wires from each servo to the OOPic controller as shown above. The black wire from the left servo should be connected to pin#2 on the OOPic's I/O connector and the black wire from the right servo should connect to pin#2 on one of the OOPic's Network connectors. Please refer to the diagrams labeled Black Servo wire I/O connector and Black Servo wire Network connector for the proper pin locations and wire connections. These diagrams are displayed below.

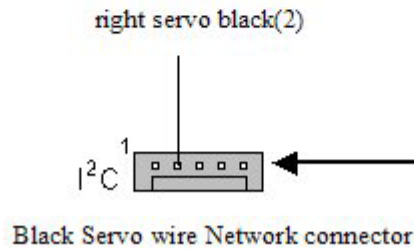
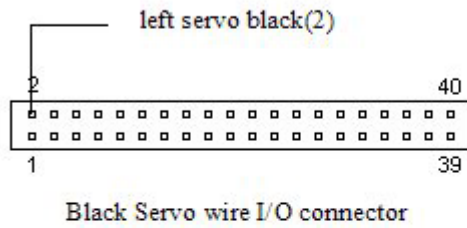
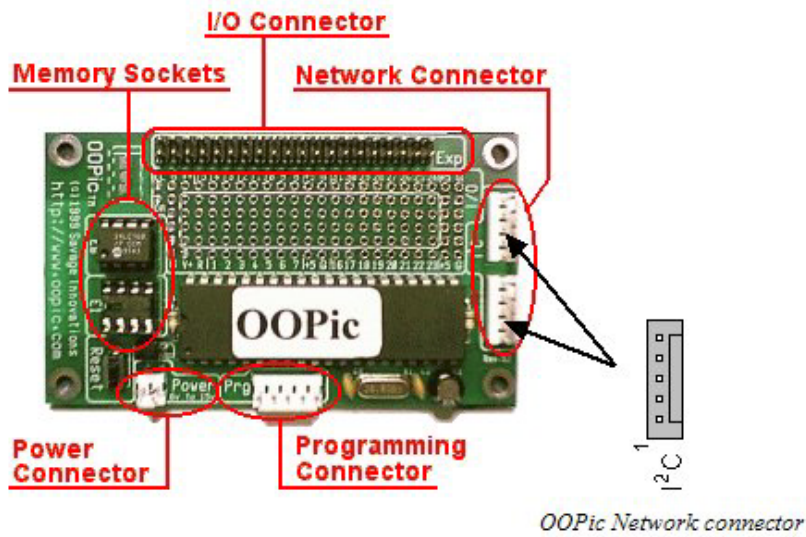
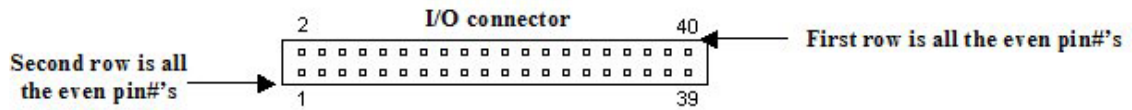

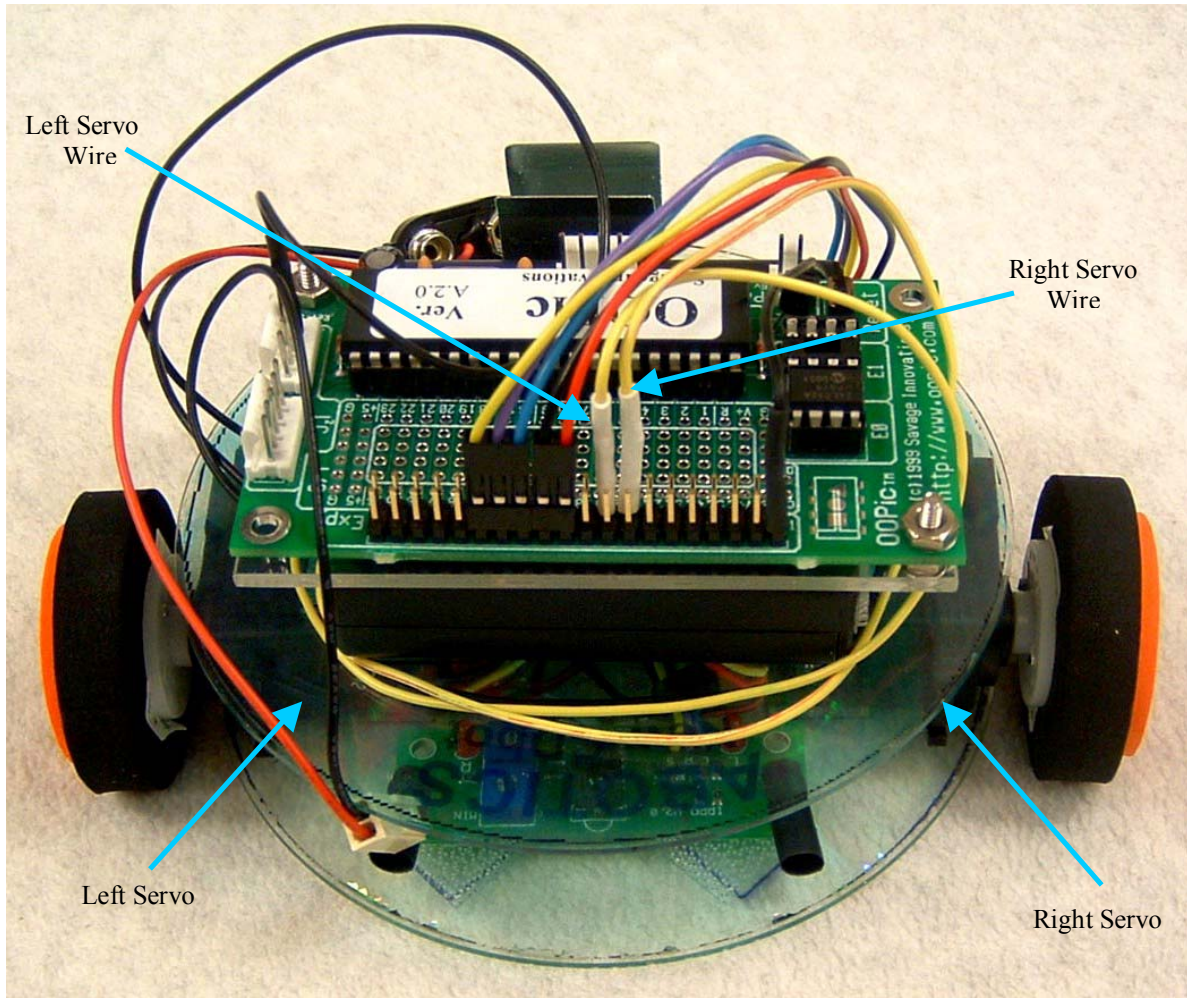

Step 12. Connect the white/yellow servo wires to the OOPic I/O connector.

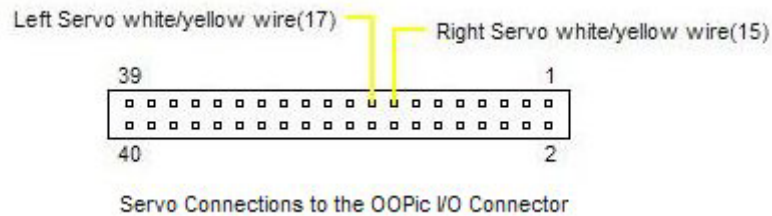

In step 12 connect each of the white/yellow servo wires to their proper place on the OOPic controller. Your NewCDbot's servos may have a white wire instead of a yellow wire or it may have yellow wire instead of a white wire. The white/yellow wire from the left servo must connect to pin#17 on the OOPic's I/O connector and the white/yellow wire from the right servo must connect to pin#15 on the OOPic's I/O connector. Please refer to the above diagram labeled White/Yellow Servo wires to I/O connector for the proper pin connections. The right servo is the servo that is to the right when viewing the front of the NewCDbot.

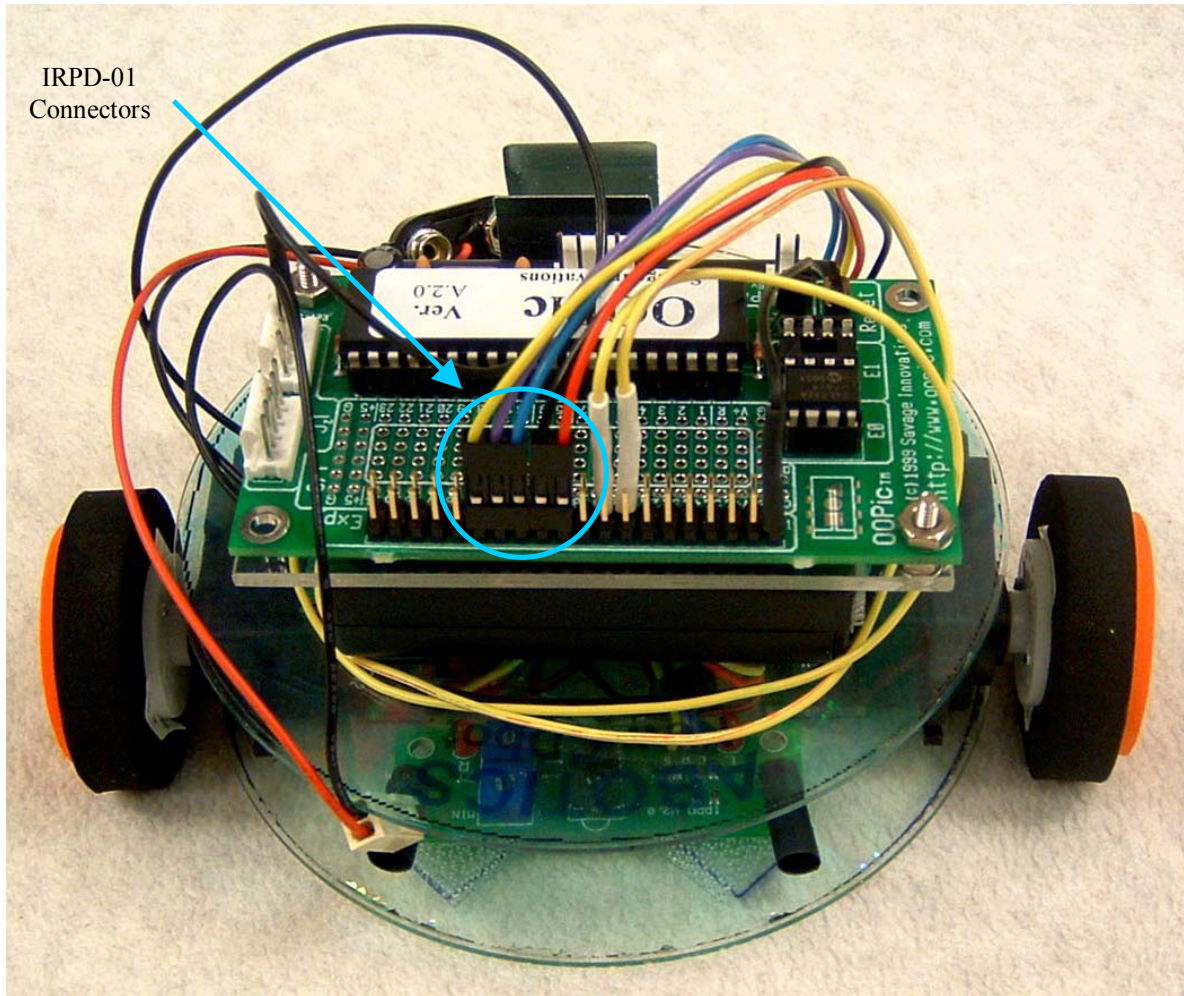

Step13. Connect the IRPD-01 wires to the OOPic I/O Connector.

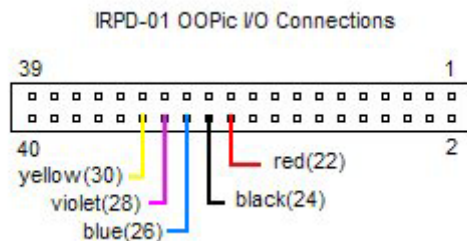

In step 13 we will connect the Lynxmotion IRPD-01 sensor to the OOPic's I/O connector. Please refer to the above diagram for the correct pin# connections that need to be made on the OOPic's I/O connector. If you improperly connect the red and black power wires of the sensor you may damage the sensor and/or the OOPic! So please be careful and take time to complete this section. When possible ask someone to double-check your wire connections. First connect the connector with the red and black wires as follows: the red wire must connect to pin#22 on the OOPic's I/O connector, the black wire must connect to pin#24 on the I/O connector. Finally, the connector with the blue, violet, and yellow wires must be connected as follows: connect the blue wire to pin#26,

the violet wire to pin#28, and the yellow wire to pin#30 on the I/O connector. Please refer to the above diagram labeled Lynxmotion IRPD I/O connections for the proper pin connections.

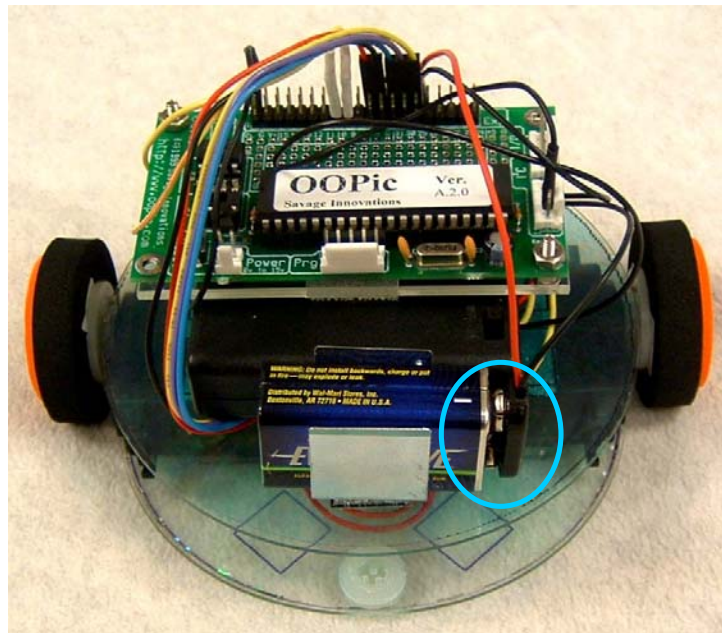

Step14. Insert and connect a 9-volt battery.

In step 14 insert a 9volt battery into the 9volt battery holder and connect the 9volt battery connector.

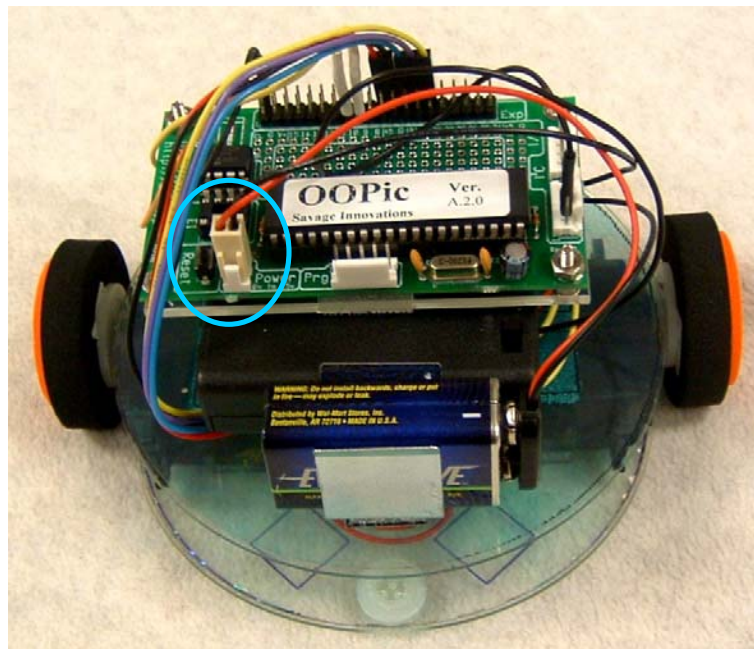

Step15. Connect the AA-battery connector to the OOPic power connector.

Finally, take the connector from the AA-battery holder, which has a black and red wire and connect it to the power connector on the OOPic. It will only connect one way so don't force the connector; try to align the small ribs on the connector.

Congratulations! You have just completed the assembly of your very own NewCDBot Robot! If you are ready to write some code for your NewCDBot, please refer to the first online tutorial for the "CDBot Programmer Compiler", http://www.abotics.com/cdbot_robot_software.htm, it will help you to get started programming your NewCDBot.